

INSTALLATION INSTRUCTIONS

CTS602 HMI BY NILAN



Combi 302 Polar Top (English)

TABLE OF CONTENTS

Safety

Power supply.....	4
Heat pump ventilation.....	4
Disposal.....	4
Ventilation unit.....	4
Heatpump.....	4

General information

Introduction.....	5
General information prior to installation.....	5
Final inspection.....	6
Ventilation Combi unit.....	6
Unit type.....	7
Product description.....	7
Overview of temperature sensors.....	8
Dimensional drawing.....	9
Functional diagram.....	10
Accessories.....	11
CO2 sensor.....	11
EM-box.....	11
Electrical after-heating element.....	11
Pollen filter.....	11
Water trap.....	11
Vibration absorbers.....	12
Flexible sound damper.....	12

Set up

Installation.....	13
Positioning of the unit.....	13
Top unit.....	13

Electrical installation

Electrical connections.....	14
Safety.....	14
Connection points.....	14
Control panel.....	15
HMI User panel.....	15
Wall bracket.....	16
Connecting the control panel.....	16
Electrical connections unit.....	17
Power supply.....	17
Unit.....	17
Electrical connection accessories.....	18
Connection to user selection and Modbus.....	18
Electrical after-heating element.....	19
External heating control system.....	20

Plumbing installation

Condensate drain.....	21
Important information.....	21
Connection bottom.....	22
Plumbing connection - accessories.....	23
Water trap with ball (option).....	23

Ventilation installation

Duct system.....	24
Legislation.....	24
Ducts.....	24
Unit.....	24
Extract air.....	25
Supply air.....	25
Roof stacks.....	25
Balancing.....	26
Important information.....	26
Balancing spouts.....	26
Pressure fall diagram.....	26

Safety

Power supply



CAUTION

Always disconnect the power supply to the unit if an error occurs that cannot be rectified via the control panel.



CAUTION

If an error occurs on electrically conductive parts of the unit, always contact an authorised electrician to rectify the error.



CAUTION

Always disconnect the power supply to the unit before opening the unit doors, for instance for installation, inspection, cleaning and filter change.

Heat pump ventilation



CAUTION

Avoid touching the pipes for the heating system in the heat pump. They can get very hot.



CAUTION

To protect the heat pump from damage, the following safety equipment has been fitted:

- Electronic monitoring of the temperature

The heat pump must undergo appropriate service inspections in compliance with current laws and regulations. This ensures the unit is maintained adequately in accordance with safety and environmental requirements.

The responsibility for maintaining the heat pump lies with the owner/user.

Disposal

Ventilation unit



Nilan's units consist mainly of recyclable materials. They must, therefore, not be mixed with household waste, but must be delivered to your local recycling center for disposal.

Heatpump



Concerning disposal of units with heat pumps, it is important to contact the local authorities for information about correct handling of these. The heatpump contains the refrigerant R134a, which is harmful to the environment if not handled correctly.

General information

Introduction

General information prior to installation

The following documents are supplied with the unit:

- Installation instructions
- Software instructions
- User manual
- Electrical diagram

Instructions can be downloaded from Nilan's website: <http://www.nilan.dk/en-gb/frontpage/download>

If you have questions regarding installation of the unit after having read the instructions, contact your nearest supplier of Nilan products, who can be found on www.nilan.dk/en-gb/frontpage/download/dealers.

The purpose of these instructions is to advise the installer on correct installation and maintenance of the unit.



ATTENTION

The unit must be started up immediately after installation and connection to the duct system. When a ventilation unit is not in operation, humidity from the rooms may penetrate into the ducts and create condensation. Condensate water may leak out of the valves and damage furniture and floors. Condensation may also form inside the unit, which can damage its electronics and fans.

The unit is delivered fully tested and ready for operation.

Final inspection

Ventilation Combi unit

How to set the unit

This list is intended for the installer to get an overview of what settings to use in consultation with the user or the builder.

Function		Settings
Setting of frequency of filter change		Days:
What level constitutes basic ventilation		Level:
Do you want low flow ventilation at low outdoor temperatures	yes/no	Level: At °C:
Do you want low flow ventilation at low air humidity	yes/no	Level:
Level - low air humidity		%
Do you want high flow ventilation at high air humidity	yes/no	Level:
Set maximum time for high air humidity		Min:
What is the desired room temperature		°C:
Should ventilation cease at low room temperatures	yes/no	°C:
Is a cooker hood connected to the ventilation system	yes/no	Level:
Do you want active cooling	yes/no	
Cooling setpoint		°C:
High ventilation in connection with cooling	yes/no	Level:

Unit type

Product description

Combi 302 Polar Top is a combined passive and active heat recovery unit with cooling function. The unit is designed for airflows up to 430 m³/h at 100 Pa external duct pressure.

The unit draws the humid, vitiated air out of the dwelling via the bathroom, WC, kitchen and utility room and introduces fresh outdoor air into habitable rooms such as living room, bedrooms and office. The cold outdoor air is heated up in the heat exchanger by the warm exhaust air.

Combi 302 Polar Top is supplied as standard with a filter sheet in the outdoor air and extract air ducts. If it is wished to filter the outdoor air for pollen, an pollen filter can be purchased as an accessory and mounted subsequent.

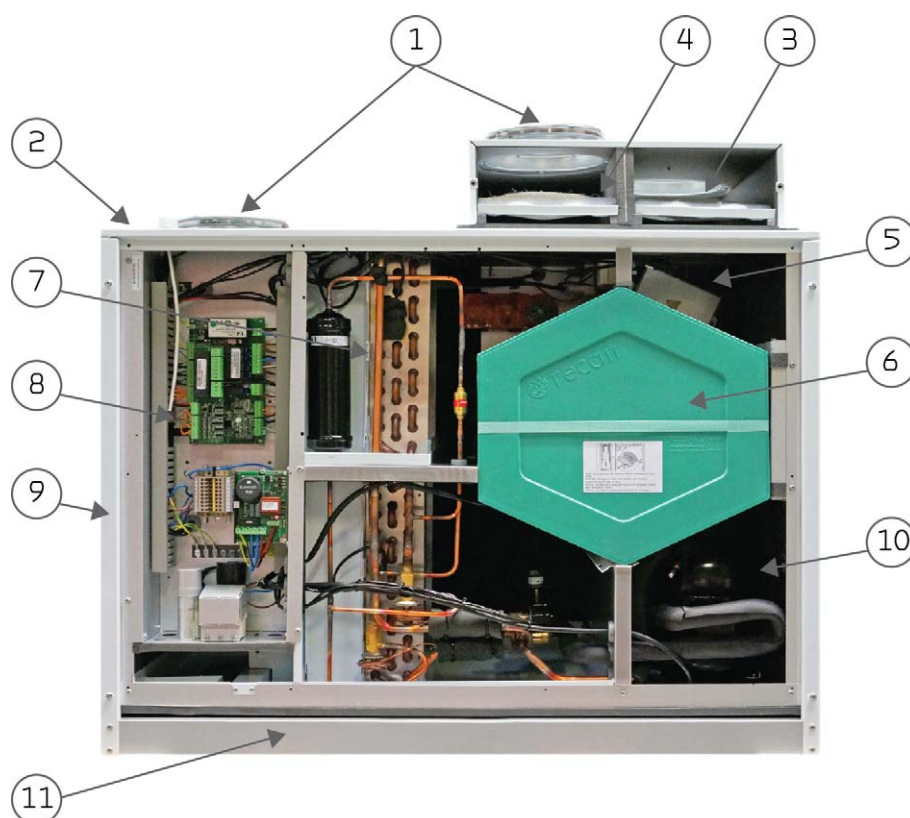

1. Duct connections
2. Electrical connections
3. Extract air filter
4. Outdoor air filter (Pollen filter is fitted here)
5. 100 % bypass damper
6. Counterflow heat exchanger
7. Heat pump
8. Automatic control system
9. Air fan
10. Pre-heating element
11. Condensate drain

Overview of temperature sensors

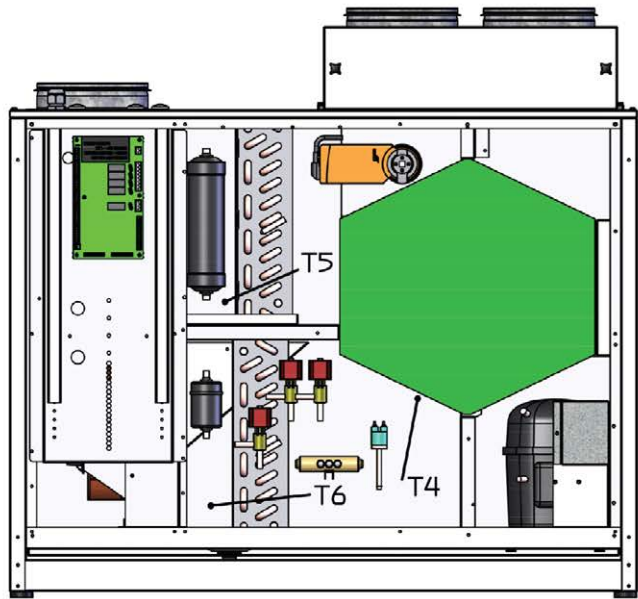
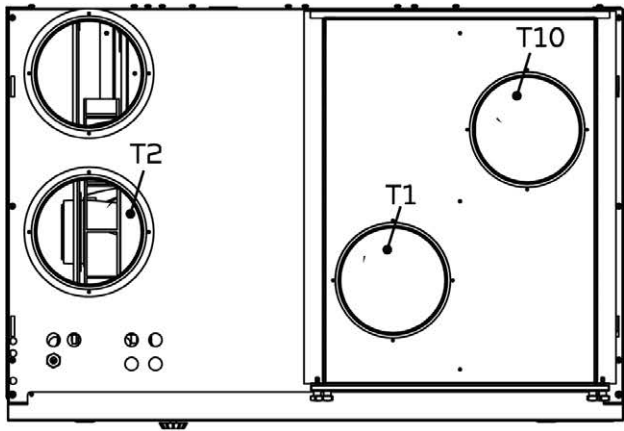

Temperature sensors in the unit

T1: Outdoor air

T2: Supply air

T4: Extract air after heat exchanger

T5: Condenser

T6: Evaporator

T10: Extract air

Temperature sensors outside the unit

T7: Supply air after heating element (accessory)

T9: On heating element (accessory)

Dimensional drawing

All dimensions are in mm.

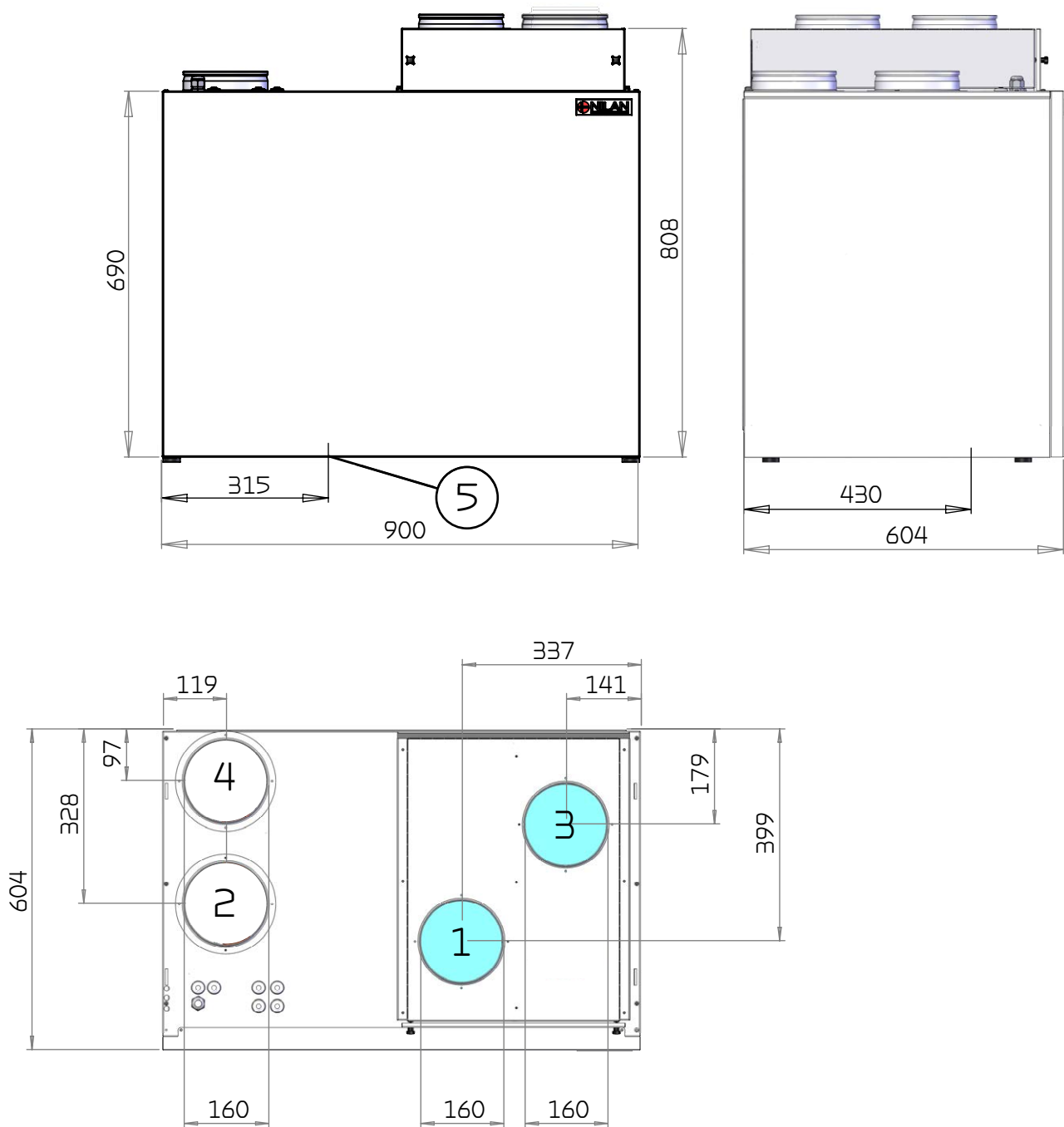

Connections:

1. Fresh air (outdoor air)
2. Supply air
3. Extract air
4. Discharge air
5. Condensate drain

Functional diagram

Heating function

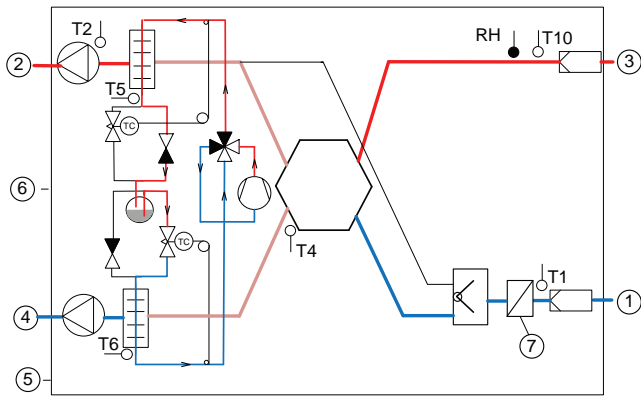

Cooling function

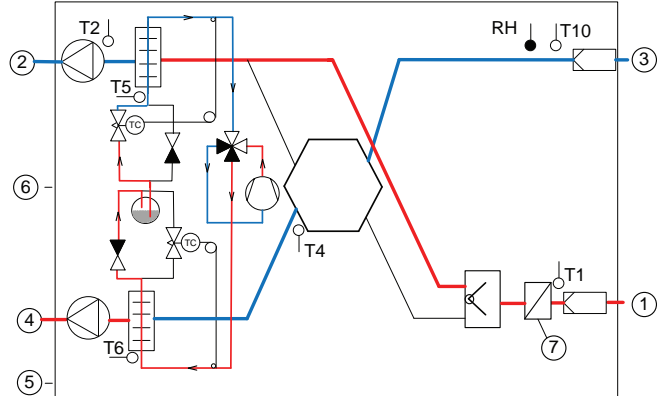

Connections

1. Outdoor air
2. Supply air
3. Extract air
4. Discharge air
5. Condensate drain
6. Electrical connection
7. Pre-heating element (frost protection)

Automation

- T1: Outdoor air sensor
T2: Supply air sensor
T4: Discharge sensor
T5: Condenser sensor
T6: Evaporator sensor
T10: Extract air sensor (room temperature)
RH: Humidity sensor

Accessories

CO₂ sensor

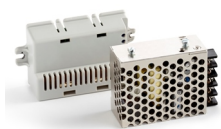

Fitting a CO₂ sensor means the ventilation speed can be pre-programmed to run higher ventilation levels in the event of high CO₂ level in the extracted air. CO₂ levels can be programmed.

EM-box



With an EM box it is possible to divide the extract air between the kitchen and the bathroom.

If a cooker hood is connected to the unit and is switched on, extract air from the bathroom will be reduced slightly to allow sufficient air for the cooker hood to extract kitchen fumes.

The EM-box has a fitted metal filter that clears the air in the cooker hood of grease particles effectively, and thereby protects the unit.

Electrical after-heating element



With an electrical after-heating element you can increase the supply air temperature to the desired level. Electrical after-heating elements are supplied for mounting in the supply air duct. Included are the necessary sensors.

Pollen filter

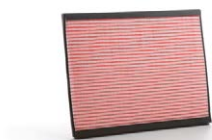

As a standard, the unit is supplied with a plate filter.

If anyone in the household suffers from a pollen allergy, you can install a pollen filter in the outdoor air intake to minimize the proportion of pollen in the indoor air.

A pollen filter also removes approx. 50 % of harmful particles in outdoor air, so a pollen filter is recommended if you live in a large city or close to a motorway.

Water trap



To ensure that condensate water can drain freely, a water trap must be installed.

You should check regularly that there is water in the trap. The water trap may dry out during late spring, summer and autumn, when no condensation is formed. If the water trap dries out, air will be sucked into the unit and condensate water will not be able to drain. This will cause water damage.

Nilan's water trap contains a ball that ensures that no air is sucked into the unit and that condensate water can drain freely.

Vibration absorbers



Four vibration absorbers are placed under the unit to ensure effective softening of the vibrations of the unit against its foundation.

Flexible sound damper



To make it easy to service the unit in the future, we recommend that you fit a flexible connection between the unit and the duct system.

Nilan's flexible sound damper absorbs sounds effectively from both the duct system and from roof stacks.

Set up

Installation

Positioning of the unit



ATTENTION

When positioning the unit, you should always consider future services and maintenance.

It must be easy to change filters, and it must, for instance, be possible to remove the heat exchanger, and to replace fans or other components.



ATTENTION

An open space of minimum 60 cm in front of the unit is recommended.



ATTENTION

The unit must be level to enable proper drainage from the condensate tray.

The unit makes little noise and produces only weak vibrations, but you should still take into account potential vibrations that can spread from the unit to individual building components. In order to separate the unit from its foundation, it is therefore recommended that you install vibration absorbers under the unit. There should be approx. 10 mm distance to other building components and to permanent fixtures.

Top unit

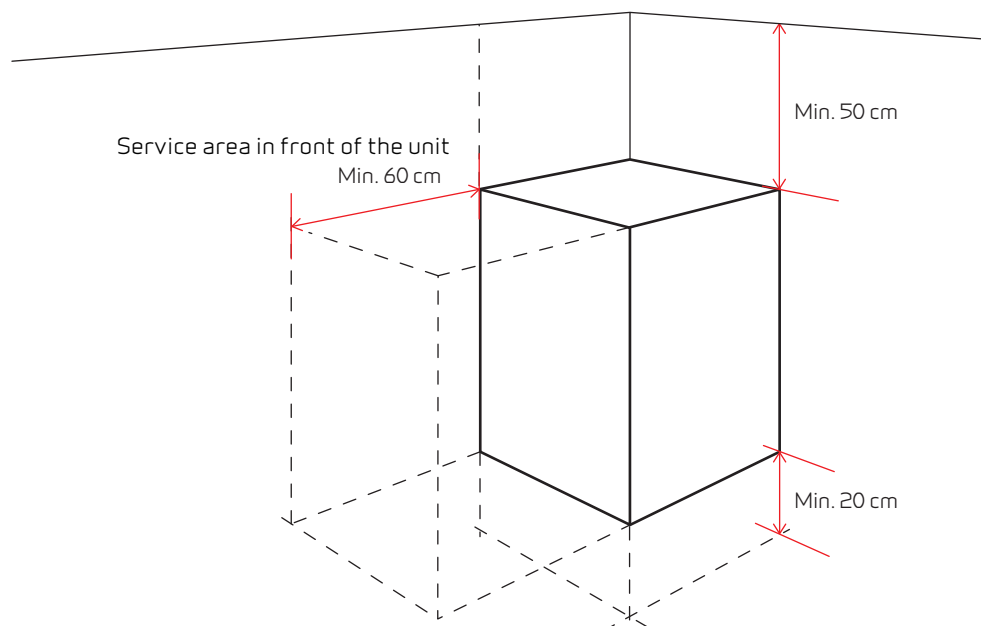

ATTENTION

If you fit flashings above the unit, there must be enough space to remove these easily.

Electrical installation

Electrical connections

Safety

 **ATTENTION** All work must be carried out by qualified persons and in compliance with existing legislation and regulations.

 **ATTENTION** It is important that the power is off, if you do work to the electrical components of the unit.

It is important to check that wires are not damaged or squeezed during connection and use.

Connection points

All connection points are on the top of the unit on the right side seen from the front.

1. Connecting 230V (remember earth wire)
2. Control panel connection
3. Connecting PC
4. Connecting to external connections

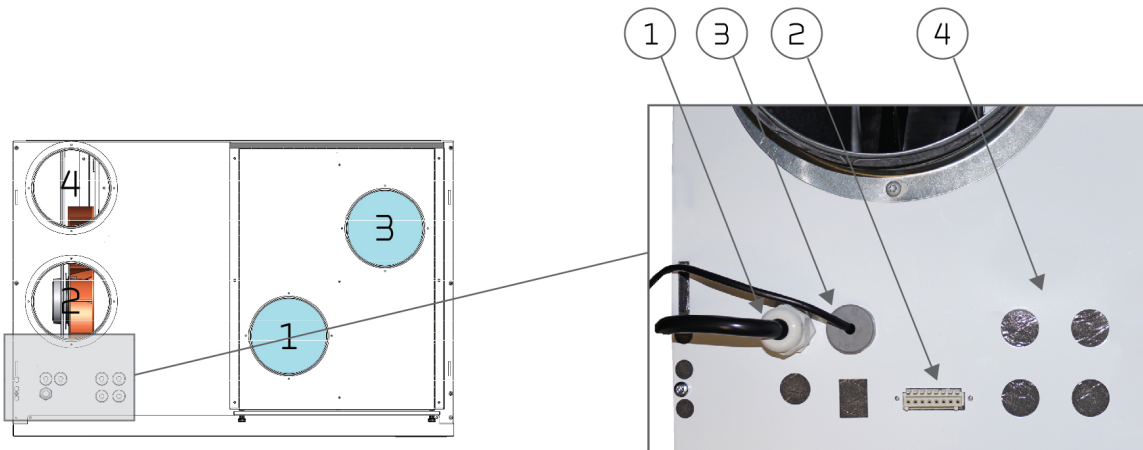

Control panel

HMI User panel

The user panel is supplied with 1½ m cable. Connect the panel to the CTS602 control system in the unit using a CAT.5e cable (max. length 50 m).



ATTENTION

If you want a longer cable, use an ordinary LAN-cable, not a crossover cable, max. 50 m.

If you want to extend the cable, please be aware of the following:

Installation in the RJ12 plug

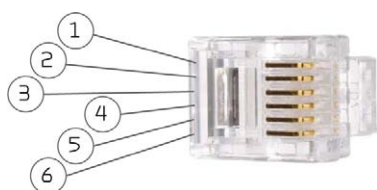

1. Empty
2. Empty
3. Green (A2)
4. Green/white (B2)
5. Brown (12V)
6. Brown/white (GND)

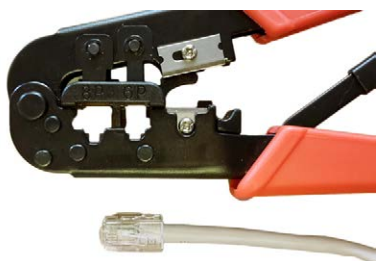

Use RJ12 plug and RJ12 crimping tool.

Installation in the 8 pole plug

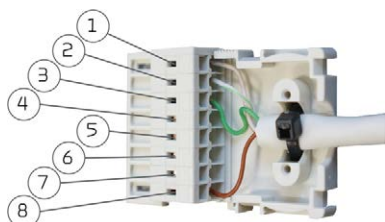

1. Brown/white (GND)
2. Green/white (B2)
3. Green (A2)
4. Empty (User selection)
5. Empty (User selection)
6. Empty (A1)
7. Empty (B1)
8. Brown (12V)

Wall bracket

Mount the HMI panel on the wall using the integrated wall bracket.

The panel should be visible so it is possible to change settings and to monitor warnings or alarms regarding operation.



The wall bracket is located at the back of the panel. You can detach it by loosening the bracket at the bottom of the panel. You can then remove it.

Mount the bracket on the wall using 2 screws.

Click the RJ12 plug into place at the bottom of the HMI panel. The wire can run down along the wall, into the wall or through the groove at the back of the panel.

Connecting the control panel



Electrical connections unit

Power supply



CAUTION

The power supply, including a safety switch, must be installed by an authorized electrician.

A power cable for connection to a power socket is included. It is important that the unit is earthed.

The unit is supplied with an EU plug for a 230V power supply. This means that, in principle, you have no protection of electrical grounding. You can secure electrical grounding by connecting the plug to a socket with a ground pin.

You can also connect an adapter for a plug with a ground pin. You can fit this plug adapter on the unit, so that the unit is secured electrical grounding to the earthing system.

Unit

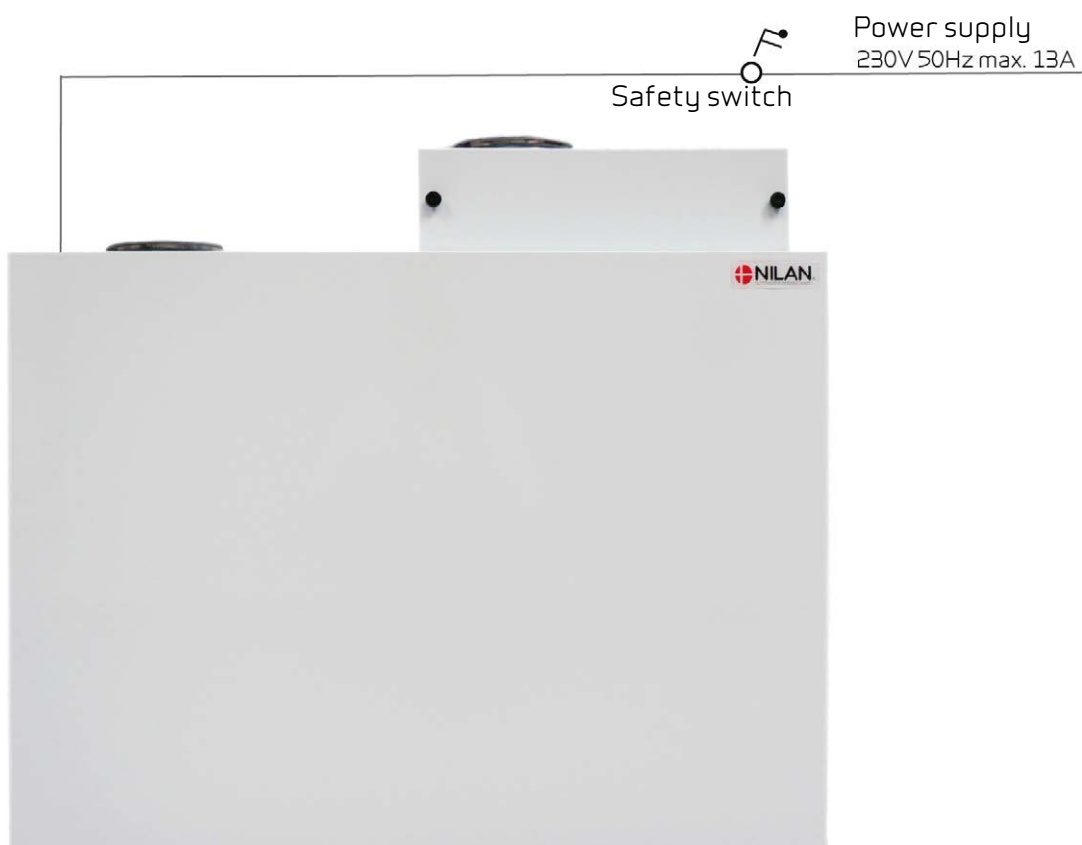

Electrical connection accessories

Connection to user selection and Modbus

User selection: Connection to user selection can be used, for instance, for controlling a cooker hood. This happens via a potential free contact in the cooker hood that sends a signal to the unit, which, in turn, increases ventilation when the cooker hood is on. You connect it using pin 4 and 5 in the 8 pole plug of the control panel.

User selection can also be used for other functions such as to create imbalance in supply air and extract air ventilation.

Modbus: You can communicate with the unit via Modbus, which can be connected in pin 1 (GND), pin 6 (A1) and pin 7 (B1) in the 8 pole plug of the control panel.

Please, consult user manual for software settings etc.

Connect the plug to the unit in point 2: Connecting the user panel.

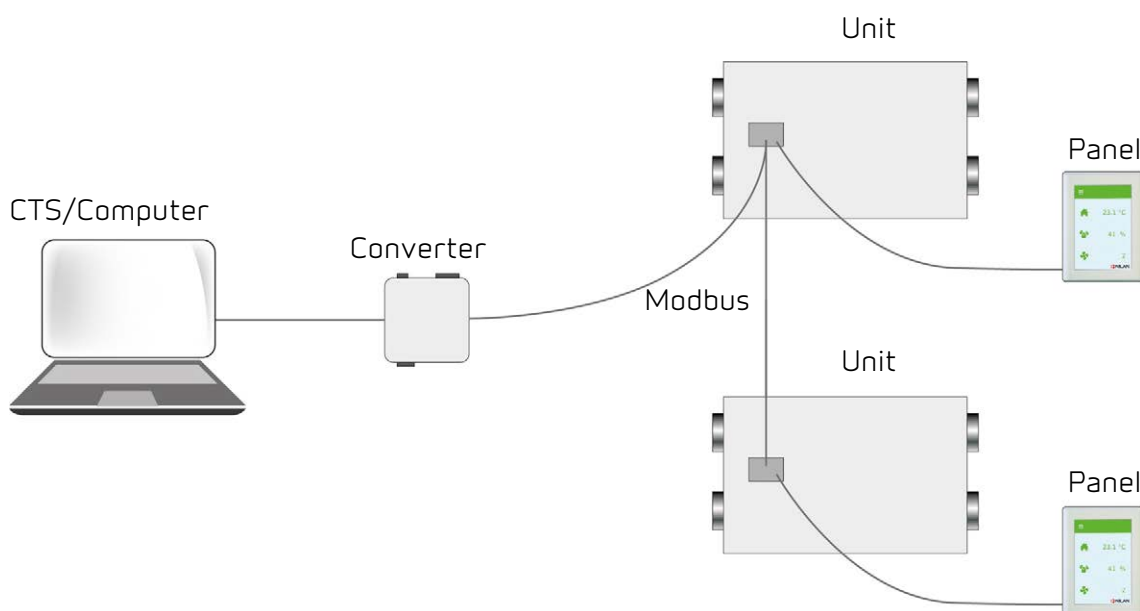
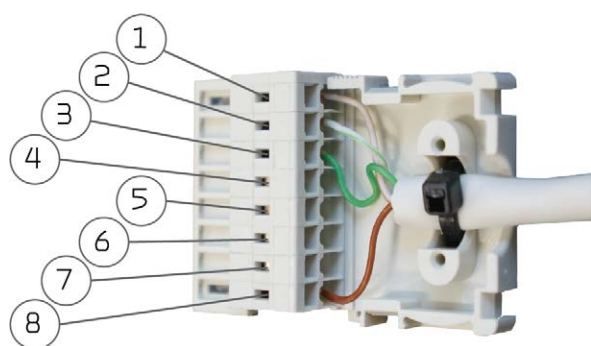

Electrical after-heating element

An after-heating element is necessary if you want to control the supply air temperature.

The electrical after-heating element can be purchased for installation in the supply air duct. The required sensor and connectors for the unit are included.

RJ 45 plug is cut off at the crimp sleeve collection and cord are mounted in the PCB.



ATTENTION

T7 temperature sensor is mounted at the air heater. T2 sensor **MUST** be disconnected from the circuit board. The T7 sensor should then be connected to where the T2 sensor was previously connected up.

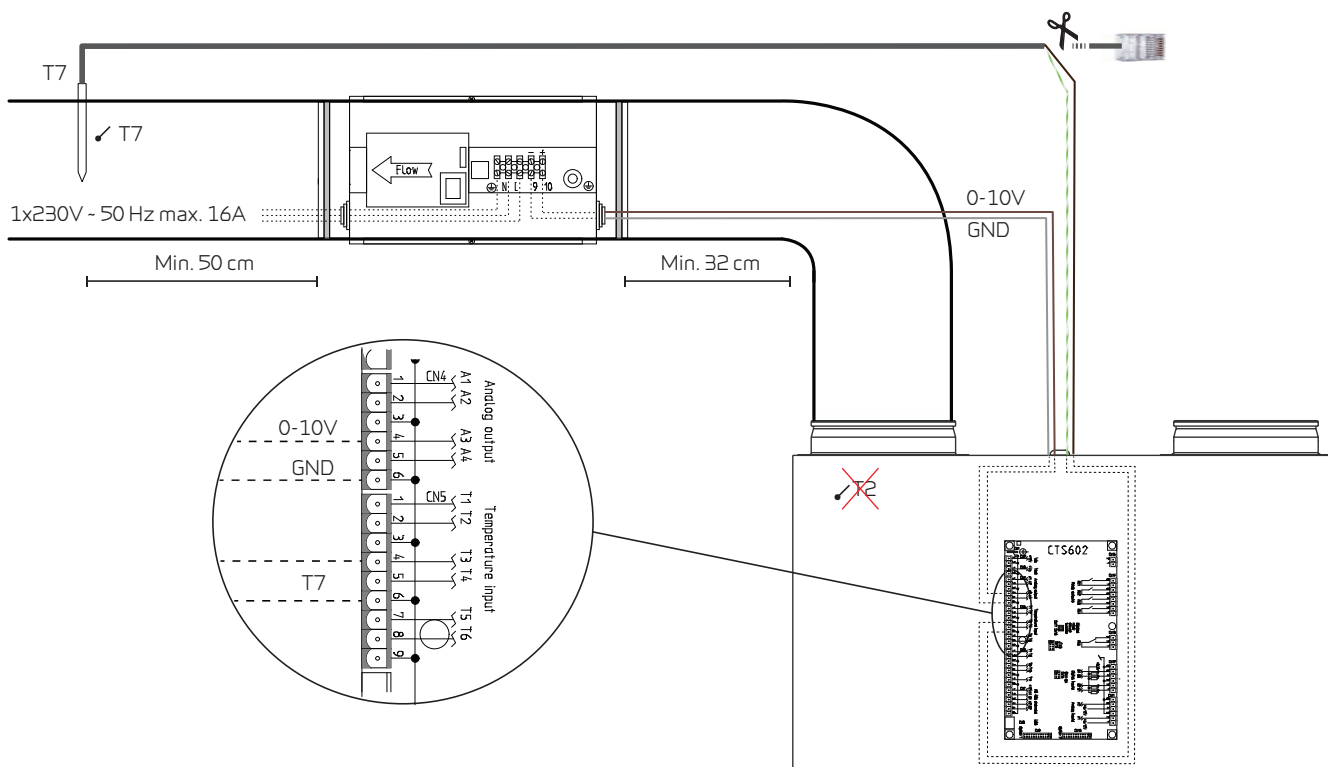

Wiring diagrams are supplied with the products.

Run the wires along the duct and through a grommet on the unit down to the circuit board. Connect the wires in accordance with the wiring diagram.



ATTENTION

The heating element must be insulated with a fire retardant insulation material. The cover of the connection box, however, must not be insulated.

Dimensional drawing:

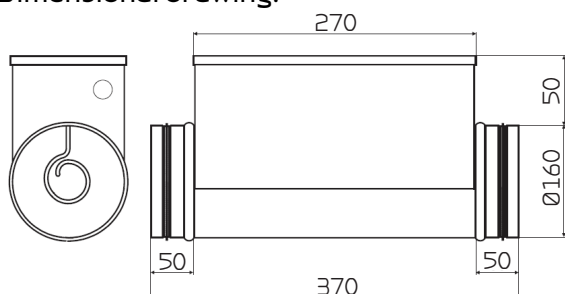

Positioning options:

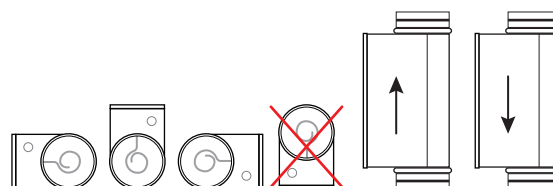

External heating control system

The unit can control an external heat supply, such as electric radiators or an underfloor heating system.

The unit monitors the room temperature and blocks the external heat supply when heating is not needed. If, through ventilation alone, the unit is unable to heat the room to the temperature you want, the external heat supply will be released until the room temperature has increased to the desired level.

Connect the external heat supply through relay 8 on the expansion PCB. Adjust the settings on the panel under the menu option: Service settings/ Temp. Regulation.

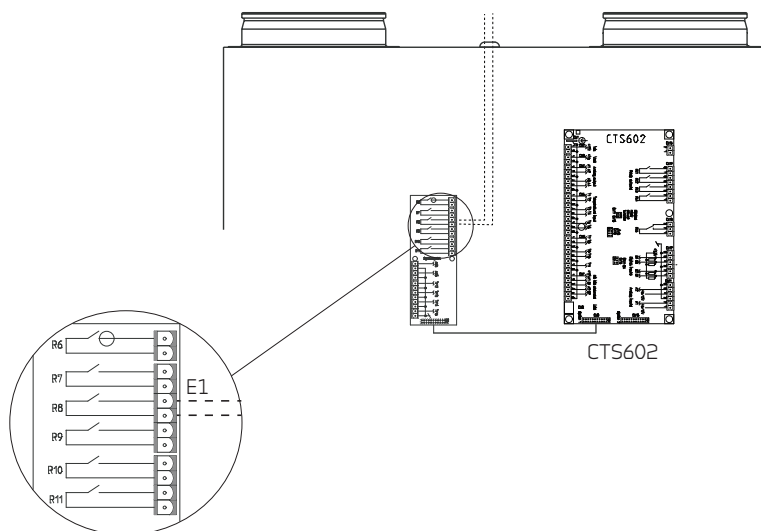

You can connect a maximum effect of 500W (The unit must be fitted with a transfer relay).

Plumbing installation

Condensate drain

Important information

The unit is supplied with an Ø20 mm condensate drain (PVC, GF-fittings).

**ATTENTION**

You **MUST** install a water trap in connection with the condensate drain to ensure that condensate water can drain away.

**ATTENTION**

If you set up the unit outside the climate screen, it is important to use a heating cable to prevent the condensate drain from icing up. Frost protection of the unit is the installer's responsibility.

During operation, negative pressure of up to 500 Pa may occur in the drain, corresponding to a 50 mm water column. The water trap must therefore be fitted as illustrated to prevent it from drying out and to avoid return flow.

The connection of the water trap must be air-tight, otherwise air will be sucked into the unit and condensate water will remain in the unit. It could cause water damage if the condensate tray overflows and condensate water runs out of the unit.

After installing the water trap, you should test it as follows (the unit must be connected to the duct system and the door must be closed):

Fill the condensate tray with water and start the unit at the highest fan speed level. Allow it to run for several minutes. Then check that there is no water in the condensate tray.

The water trap may dry out and prevent water from draining off the condensate tray, as air will then blow into the unit. The water trap should therefore be checked regularly, especially at the end of the summer, and it should be filled with water if necessary. Increasing the height of the water trap beyond the minimum requirements will minimize the need for refilling.

**INFO**

Nilan offers a water trap with a ball. The ball ensures that no air blows into the unit through the condensate drain if the water trap dries out. This ensures that water in the condensate tray can drain off, which makes it unnecessary to check the condensate drain quite so often.

Connection bottom

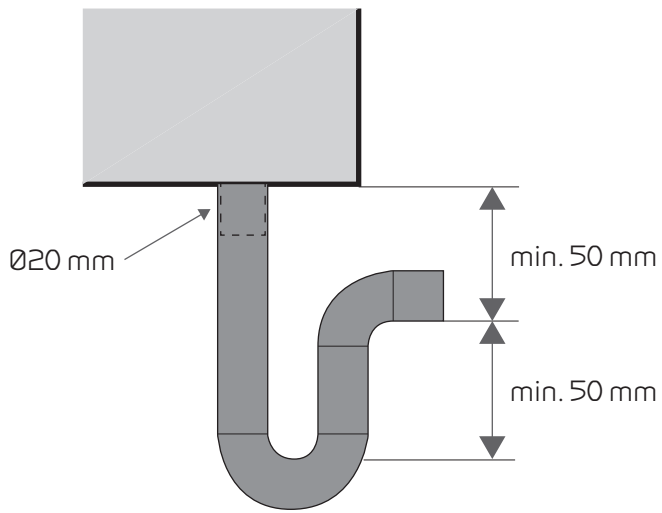

Connection of water trap generally

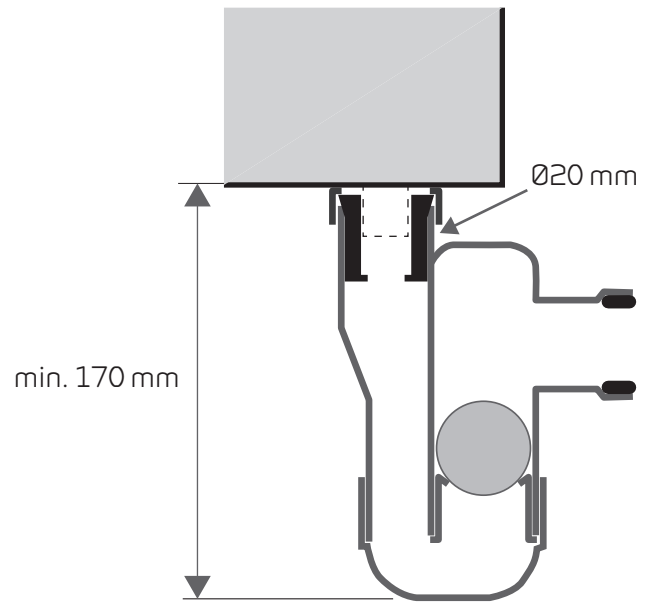

Connecting Nilan's water trap with ball

Plumbing connection - accessories

Water trap with ball (option)



Connection options with Nilan's water trap:

1. Water trap with $\varnothing 32$ mm reducing fitting
2. Reducing fitting for $\varnothing 20$ mm
3. Reducing fitting for $\frac{3}{4}$ " RG
4. Reducing fitting for $\frac{1}{2}$ " tube

Dimensional drawing:

All measurements are in mm.

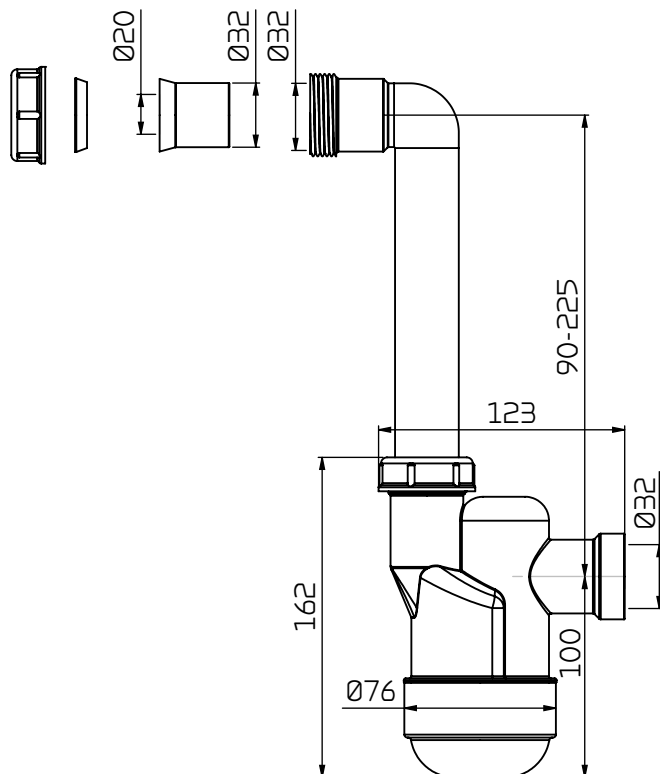

Ventilation installation

Duct system

Legislation



ATTENTION

All work must be carried out by qualified persons and in compliance with existing legislation and regulations.

Ducts

There are two systems by which to lead air through the house.

Spiral ducts

The spiral ducts are made from metal and are cut to size using an angle grinder. They are then connected using bends and manifolds and are fitted in accordance with the blueprint. The ducts are typically laid on the tie beams and are fixed with perforated band or they are suspended using suspension band. Avoid unnecessary bending of the ducts.

To prevent sound from being transmitted from room to room, you should install silencers for each room.

The ducts must be insulated to prevent heat loss and condensation. In some cases this can be avoided if the ducts are run through the general insulation or inside the climate screen.

NilAIR tubes

NilAIR tubes constitute a flexible system that is easy to install. You can easily cut the tubes to size with a Stanley knife and then situate them in accordance with the blueprint without having to use bends and manifolds. You install a manifold box after the unit and let the tubes run from the box out to the individual rooms.

With NilAIR tubes you do not need to install silencers for every room, as there is no risk of sound transmission.

If you lead the tubes outside the climate screen, they must be insulated to avoid heat loss and condensation. This is simpler than using spiral ducts, as NilAIR tubes are easily led through ordinary insulation.

NilAIR tubes are more flexible than spiral ducts and you can therefore run the tubes in places that are unsuitable for ordinary spiral ducts.

Unit

Nilan recommends that you install a flexible connection between the unit and the duct system.

This is to avoid vibrations from the unit being transmitted to the duct system, but also to lighten future services of the unit that will make it necessary to move the unit.

Nilan offers flexible Sound Flex tubes that provide a flexible connection between the unit and the duct system, but also reduce the sound transmission from the unit to the duct system.

The Sound Flex tubes are insulated against condensation. It may, however, be necessary with further insulation in order to comply with local requirements to insulation of duct systems.

Extract air

Install exhaust air valves in rooms that generate humidity. Place them strategically where they can extract humidity most effectively.

Rooms that generate humidity:

- Bathroom
- Lavatory
- Kitchen
- Utility room

Supply air

Install supply air valves in living areas. Place them strategically so they cause minimum discomfort. It is, for instance, not recommended that you install supply air valves in areas where people are inactive, as the supply air may be experienced as draughty.

Living areas:

- Sitting room
- Living room
- Bedroom
- Home-office

Roof stacks

The position and design of air intake and air discharge should limit pressure oscillations in the ventilation unit caused by wind. Their position should also prevent birds and other animals from getting in. Finally, the position and design should ensure that air intake and the connected duct system are kept free of plants and foreign objects.

You must place the air intake so that the risk of a short-circuit from the discharge air is minimized, with attention to the prevailing wind direction.

The air intake should be placed at least 0.5 m from the roof surface. On black, flat roofs the distance from the roof to the underside of the intake should be at least 1 m to ensure that warm air is not drawn into the building in the summer. Air intakes should be located on the northern or eastern sides of pitched roofs.

You should also install a silencer between the unit and the roof stacks to prevent noise from disturbing your surroundings.

Balancing

Important information



ATTENTION

To ensure the ventilation system operates optimally, it is important that it is balanced correctly. We recommend that experts do this.

It is important to measure the total supply air and the total extract air. The system must have a minimum vacuum, which means it must draw out more air than it blows in. This will prevent dampness from being forced into the construction of the building.

Balancing spouts

The unit is equipped with balancing spouts to measure the supply air and the extract air volumes.

The line chart can be used for setting, roughly, the main air volume at dry operation without condensation.

At the extract air side the difference in pressure dp_{3-4} [Pa] is measured between the spouts marked 3 and 4. You can read the air volume qv [m³/h] on the line chart.

At the supply air side the difference in pressure dp_{1-2} [Pa] is measured between the spouts marked 1 and 2. You can read the air volume qv [m³/h] on the line chart.



ATTENTION

The capacity in the pressure loss diagram is based on a dry exchanger.

Pressure fall diagram

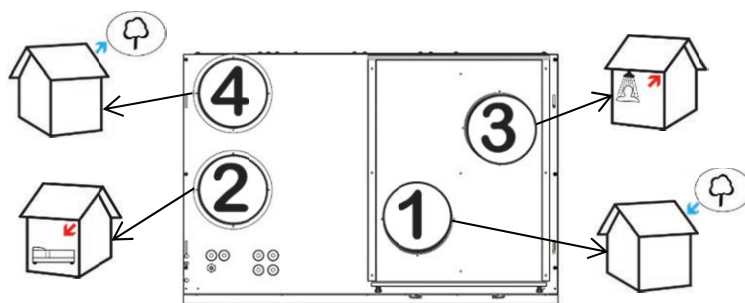
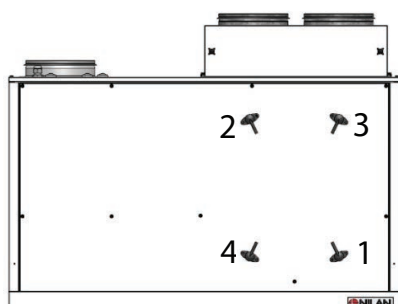

The measuring connectors are inside behind the top front panel.

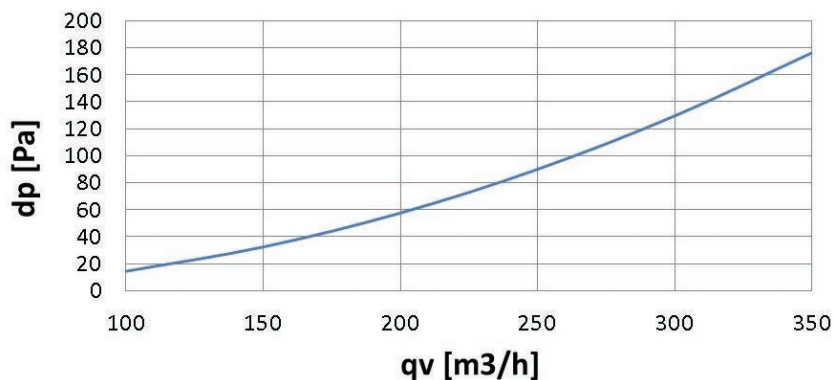

United Kingdom:

SL Services
25 St Leonards Road, Horsham
RH13 6EH West Sussex

Tlf. +44 (0) 7919 444452

stuart315@aol.com
www.nilanuk.com

Ireland:

Nilan Ireland
Ballylahive, Abbeydorney

Tlf. +353 (0) 87 9798361

maurice@nilan.ie
www.nilanireland.ie



Nilan A/S
Nilanvej 2
DK-8722 Hedensted

Tlf. +45 76 75 25 00
Fax +45 76 75 25 25

nilan@nilan.dk
www.nilan.dk